

- RCG 系列單向減壓閥是屬於支回路，其功能有二：
 - 用於設定低於主回路之壓力。
 - 可利用遠程控制口，作遠程控制用途。
- One-way pressure reducing with check valve is used branch circuit there are two functions below:
 - Using to set the pressure below of the main hydraulic circuit.
 - By using the remote control port for operation of remote control.

RCG-03.06.10

型號意義 How to order :

R C G - 06 - ※
 1 2 3 4 5

1	系列號	Series
2	附止回閥	With check valve
3	板式連接	SUB-Plate mounting
4	口徑代號	Valve size 03:3/8", 06:3/4"
5	壓力調整範圍	Pressure adjusting range

產品規格 Specification :

名稱 Name	口徑 Valve Size	型號 Model	壓力調整範圍 Pessure Adj. Range (Kgf/cm ²)	最大流量 Max. Flow (ℓ/min)	重量 Weight (Kg)
減壓閥附止回閥 Reducing pressure with check valve	3/8	RCG-03	B: 7~70	50	5.5
	3/4	RCG-06	C: 35~140	125	8.2
	1-1/4	RCG-10	H: 70~225	250	13.8

附件 Attachment :

型號 Model	安裝螺絲 Mounting bolts		O 型環 O-Ring	
RCG-03	M10 x 75L	4 支 piece	JIS B 2401-1B-P9 1 條 piece	JIS B 2401-1B-P18 2 條 piece
RCG-06	M10 x 85L	4 支 piece	JIS B 2401-1B-P9 2 條 piece	JIS B 2401-1B-P29 2 條 piece

圖形符號 Graphic symbol :

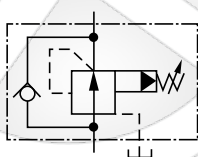
RCG

RCG-03.06.10

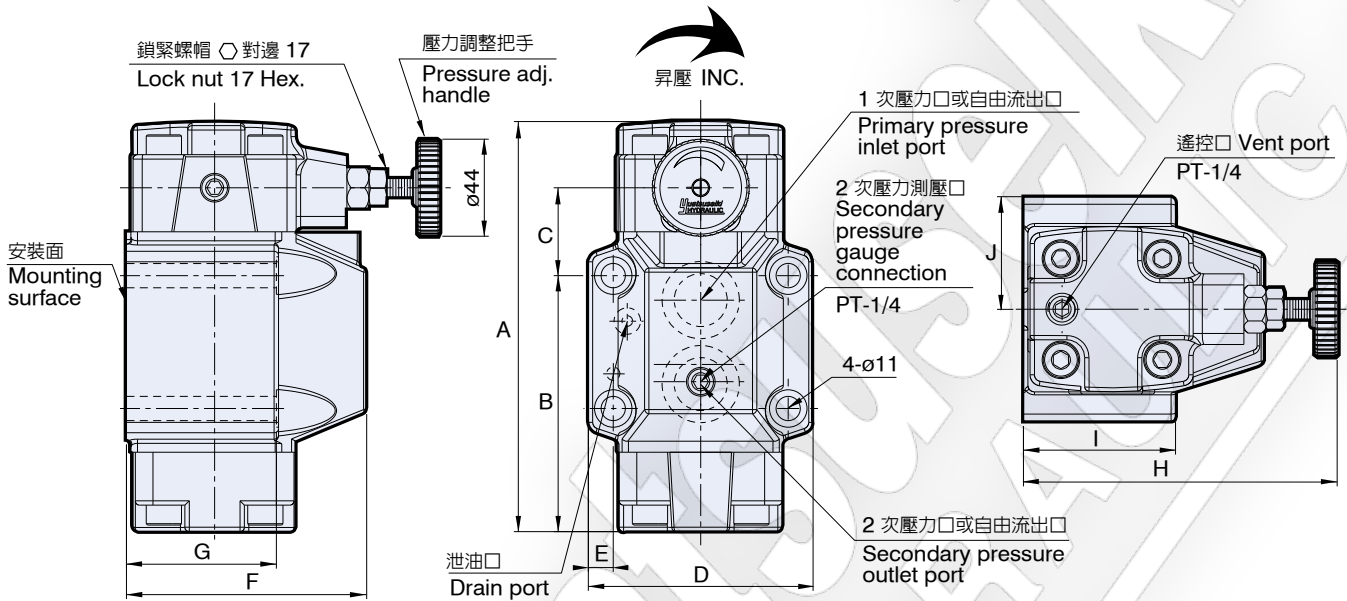

單位 Unit : mm

型號 Model	A	B	C	D	E	F	G	H	I	J
RCG-03	160	94.9	40.6	89	11.15	90	58	142.7	59	44.5
RCG-06	181	111.65	39.85	102	11.3	109	68	142.5	69	51
RCG-10	222	149	44.9	119	11.1	131	80	150	81	59.5

性能曲線圖 Performance curves

■ 流量-壓力特性曲線圖

The characteristic curve chart of Flow vs. Pressure

使用油：黏度 Test fluid viscosity: 35mm²/s {cSt}
比重 Specific gravity of 0.850

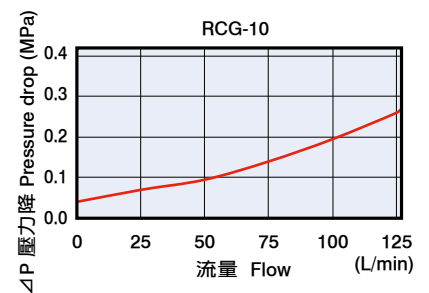
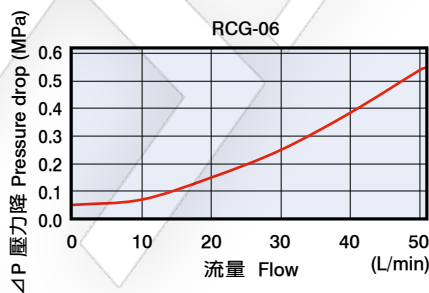
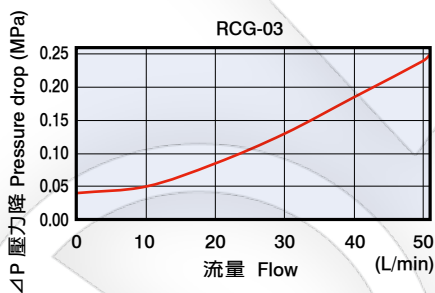

■ 粘度係數表 Viscosity

粘度	mm ² /s {cSt}	15	20	30	40	50	60	70	80	90	100
Viscosity	SSU	77	98	141	186	232	278	324	371	471	464
係數 Coefficient		0.81	0.87	0.96	1.03	1.09	1.14	1.19	1.23	1.27	1.30

爆炸圖 How to order for a complete assembled valve

RCG-03.06.10

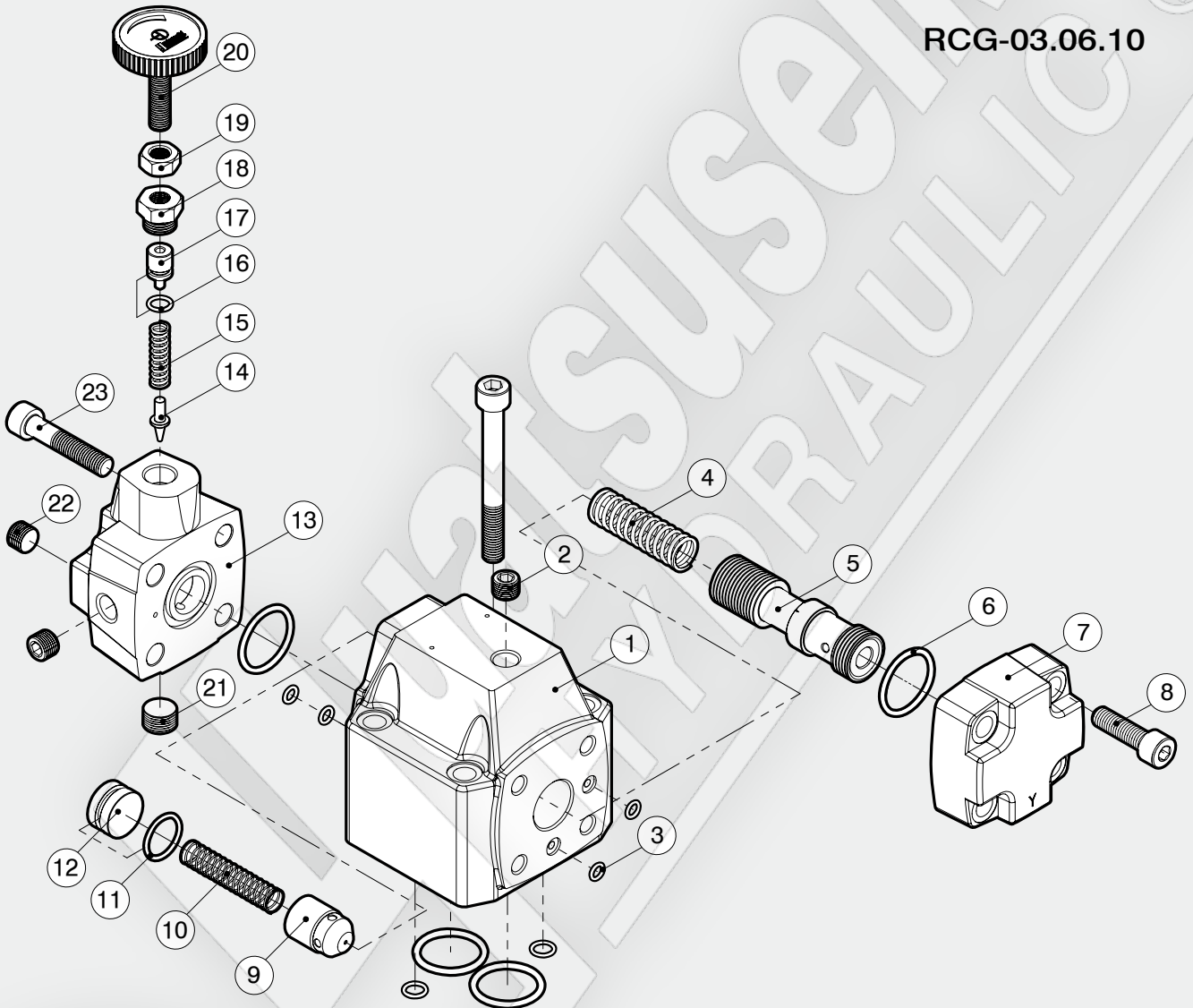

項次編號 No.	品名 Name of parts	數量 Q
1	本體 Body	1
2	PT 1/4	1
3	RCG-03.06 JIS B 2401-1B-P6	4
	RCG-10 JIS B 2401-1B-P9	4
4	彈簧 Spring	1
5	心軸 Spool	1
6	RCG-03 JIS B 2401-1B-G25	2
	RCG-06 JIS B 2401-1B-G30	2
	RCG-10 JIS B 2401-1B-P34	1
7	閥蓋 Cover	1
8	RCG-03 M8 x 35L	4
	RCG-06 M10 x 35L	4
	RCG-10 M12 x 40L	4
9	槍子閥 Check valve	1
10	止回閥彈簧 Spring	1
11	RCG-03 JIS B 2401-1A-P12	1

項次編號 No.	品名 Name of parts	數量 Q
11	RCG-06 JIS B 2401-1A-P20	1
	RCG-10 JIS B 2401-1A-P20	1
12	推桿 Push rod	1
13	壓力調整閥蓋 Cover	1
14	針閥 Pilot poppet	1
15	彈簧 Spring	1
16	JIS B 2401-1A-P9	1
17	推桿 Push rod	1
18	把手螺母 Nut	1
19	六角螺母 Nut	1
20	壓力調整把手 Pressure adj. handle	1
21	PT 3/8	1
22	PT 1/4	2
	RCG-03 M8 x 45L	4
23	RCG-06 M10 x 45L	4
	RCG-10 M12 x 45L	4